

P E R M I T

CITY OF NAPOLEON
255 W. RIVERVIEW AVE
NAPOLEON, OHIO 43545

DIVISION OF BUILDING & ZONING
PH (419) 592-4010
FAX (419) 599-8393

PERMIT NO: 98199

DATE ISSUED: 06-29-98

ISSUED BY: MBS

JOB LOCATION: 8 LAKEVIEW DR

EST. COST: 900.00

LOT #:

SUBDIVISION NAME:

OWNER: KUSER, SHARON
ADDRESS: 8 LAKEVIEW DR
CSZ: NAPOLEON, OH 43545
PHONE: 419-592-5569

AGENT: SELF
ADDRESS:
CSZ:
PHONE:

USE TYPE - RESIDENTIAL:

OTHER:

ZONING INFORMATION

DIST: R-1 LOT DIM: AREA: FYRD: 75 SYRD: 10 RYRD: 10
MAX HT: 18 # PKG SPACES: # LOADING SP: MAX LOT COV:

BOARD OF ZONING APPEALS:

WORK TYPE - NEW: X REPLMNT: ADD'N: ALTER: REMODEL:

WORK INFORMATION

SIZE - LGTH: 16 WIDTH: 8 STORIES: LIVING AREA SF:
GARAGE AREA SF: HEIGHT: BLDG VOL DEMO PERMIT:

WORK DESCRIPTION
SHED (16 X 8)

FEE DESCRIPTION	PAID DATE	FEE AMOUNT DUE
BUILDING PERMIT		3.00

TOTAL FEES DUE 3.00

6-29-98

DATE

Thomas W. York

APPLICANT SIGNATURE

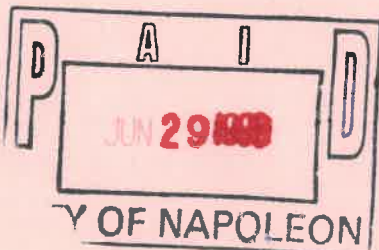

16' x 8' SHED

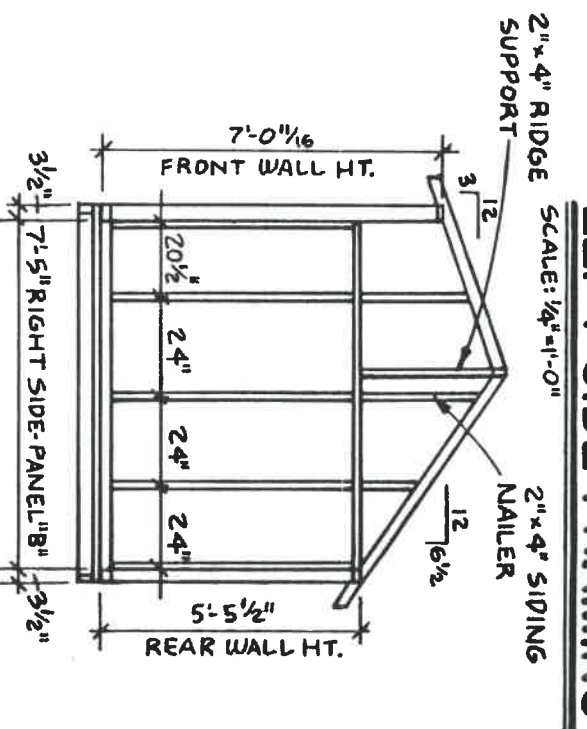
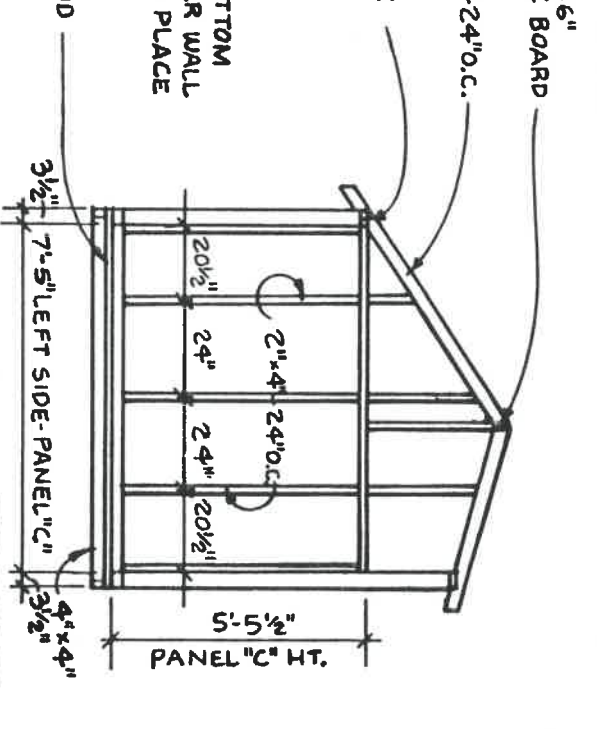
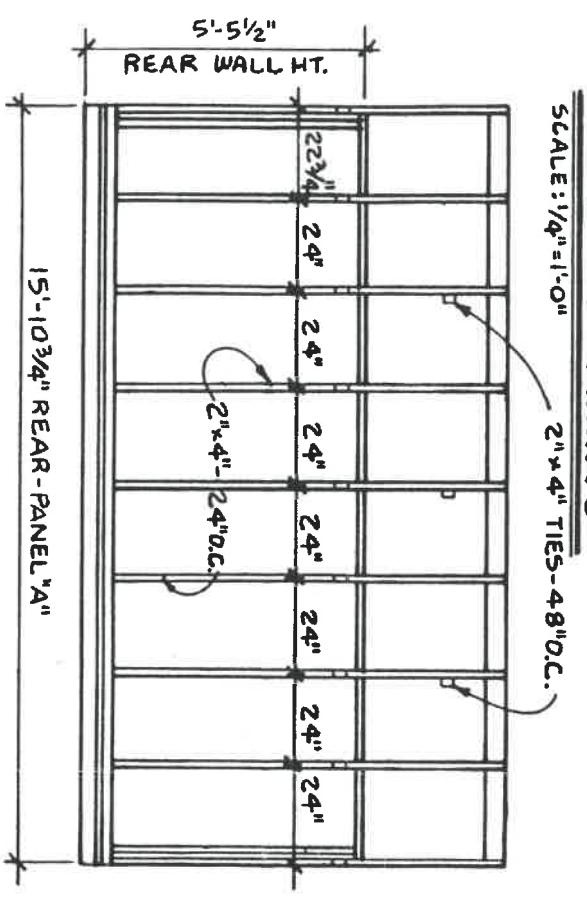
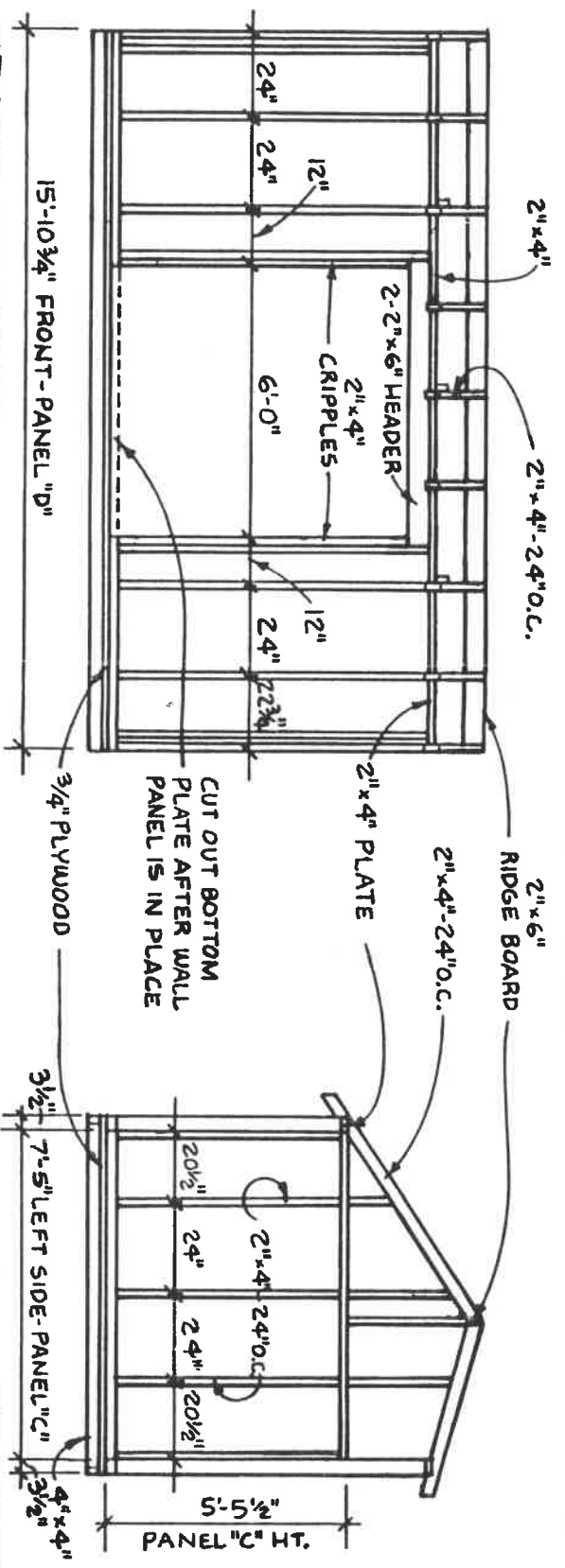

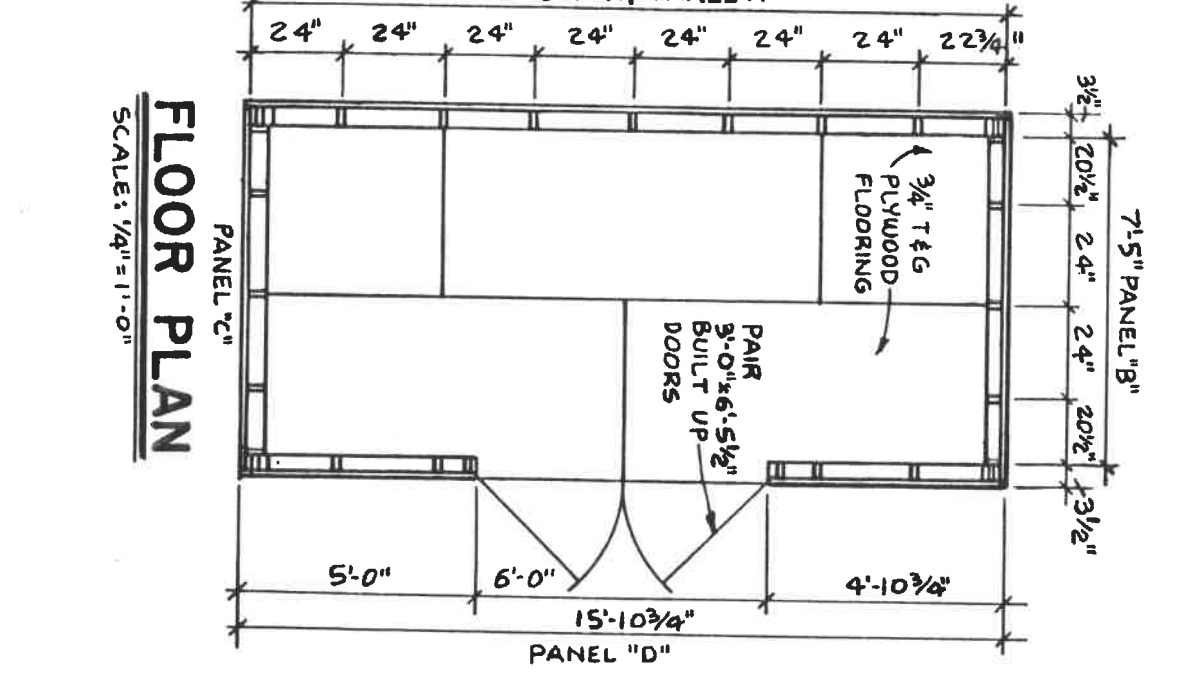
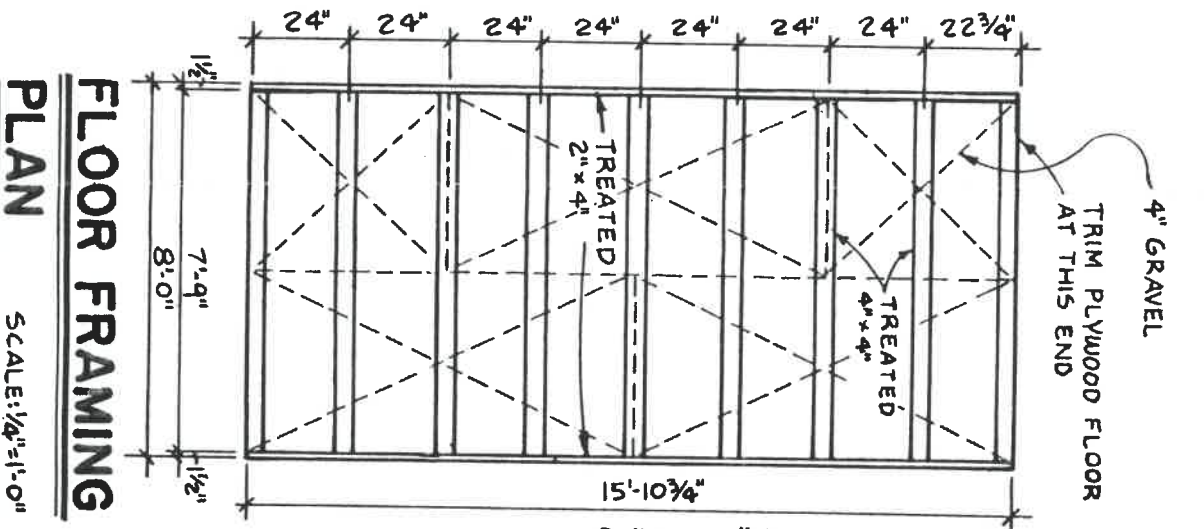
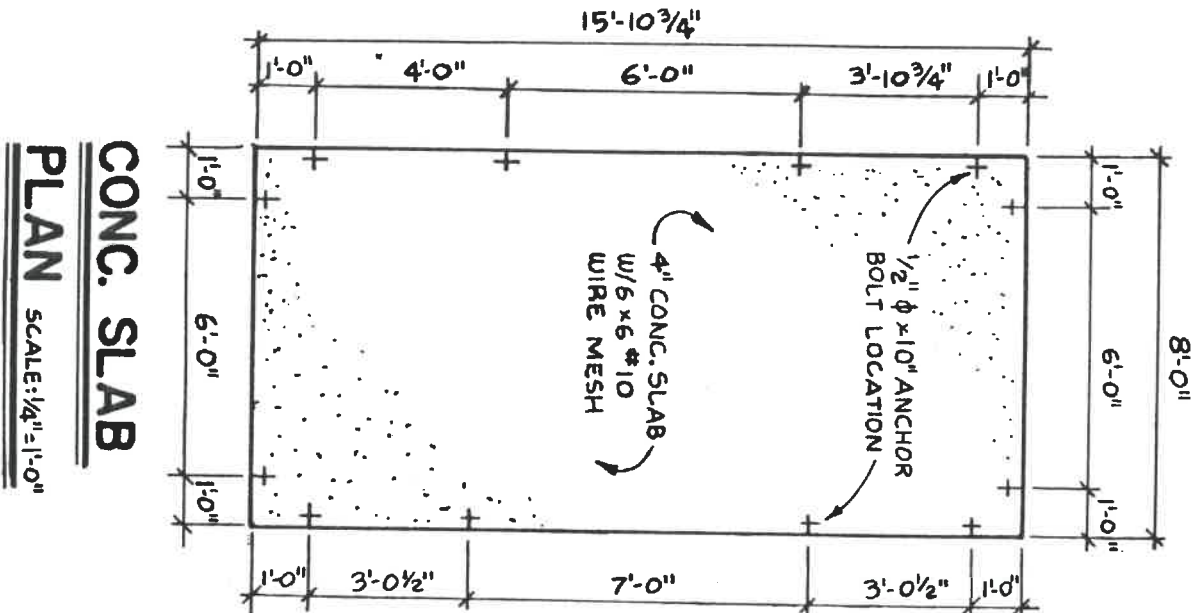



LAKENVIEW

127.50

SCANNED